

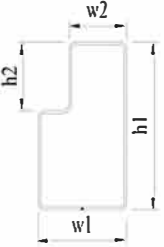

Equipment Step Beam Capacity Chart

Depth Loading Capacity		Step Tube																
				<table border="1"> <tr><th>TYPE</th><th>SIZE</th></tr> <tr><td>h1</td><td>see table</td></tr> <tr><td>h2</td><td>1-5/8"</td></tr> <tr><td>w1</td><td>2-1/2"</td></tr> <tr><td>w2</td><td>1-5/8"</td></tr> </table>		TYPE	SIZE	h1	see table	h2	1-5/8"	w1	2-1/2"	w2	1-5/8"			
TYPE	SIZE																	
h1	see table																	
h2	1-5/8"																	
w1	2-1/2"																	
w2	1-5/8"																	
h1	3" (76.2mm)	3.5" (88.9mm)	4" (101.6mm)	4" A (101.6mm)	4 1/2" (114.3mm)	5" (127mm)	5.5" (139.7mm)	6" (152.4mm)	6.25" (158.75mm)	6.25" A (158.75mm)								
Connector	3 rivets	3 rivets	3 rivets	3 rivets	3 rivets	3 rivets	3 rivets	4 rivets	4 rivets	4 rivets								
Thickness	1.5mm	1.5mm	1.75mm	1.5mm	1.7mm	1.7mm	1.7mm	1.9mm	1.9mm	2.1mm								
48"	7181	9200	10000	9200														
72"	3165	4693	8897	7094														
92"	1931	2864	5430	4330	6194	7860												
96"	1773	2628	5000	3973	5686	7215	9232											
100"	1633	2421	4591	3661	5238	6645	8504											
104"	1509	2237	4242	3383	4840	6141	7859											
108"	1398	2074	4000	3135	4600	5692	7285	10179	11288									
112"		1927	3655	2915	4169	5291	6770	9461	10493									
116"		1797	3406	2716	3886	4930	6309	8816	9778									
120"		1678	3182	2536	3629	4606	5894	8236	9134	10070								
124"			2979	2375	3398	4312	5518	7711	8550	9428								
128"			2795	2228	3188	4045	5177	7234	8022	8845								
136"			2474	1972	2823	3582	4583	6404	7102	7831								
140"			2334	1861	2662	3379	4324	6042	6700	7388								
144"			2206	1758	2516	3193	4086	5710	6332	6982								

Remarks:

1. All capacities are pair of beams based on uniformly distributed loads.
2. Deflection are limited to 1/180.

Upright Frame Capacity Chart

Upright Profile – Style – Frame Capacity by Gauge

	3" x 3" Bolted Frame				
Beam Spacing	16GA	15GA	14GA	13GA	12GA
36"	12741	18921	23453	29118	30574
42"	12370	18370	22770	28270	29684
48"	11380	17380	21780	27280	28644
54"	10390	16390	20790	26290	27605
60"	9400	15400	19800	25300	26565
66"	8410	14410	18810	24310	25526
72"	7420	13420	17820	23320	24486
78"	6430	12430	16830	22330	23447
84"	5440	11440	15840	21340	22407
90"	4450	10450	14850	20350	21368
96"	3460	9460	13860	19360	20328